



Butterfly Valve (Wafer) with Gear Operator

HPW

Technical Features

- **Sizes available (Nominal) :** DN65/2 1/2", DN80/3", DN100/4", DN150/6" and DN200/8".
- **Pressure data :**
Working pressure : 20.7 bar (300 psi)
Max. test pressure : 41.3 bar (600 psi)
- **Finish :** Fusion bonded Nylon 11 coating.
- **Connections :** Wafer style carefully designed to fit between the following flange types;
BS 4504/DIN 2501/ISO 2084 PN10 and PN16.
ANSI B16.1 Class 125.
BS 10 Table E.
- **Supervisory Switches :**
The gearbox is fitted with one internal supervisory position switch and one internal auxiliary switch.

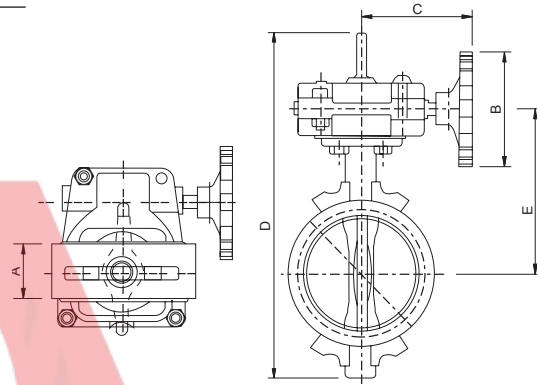

Control Valves



Butterfly Valve (Wafer) with Gear Operator - HPW

Physical Data

Nominal Pipe Size		Dimensions (mm / inch)					Reference	Weight (kg / lbs)
Metric	inch	A	B	C	D	E		
DN65	2 1/2"	46.6 / 1.84	128 / 5.0	135 / 5.3	343 / 13.5	166 / 6.5	HPW-0250	8 / 17.6
DN80	3"	46.6 / 1.84	128 / 5.0	135 / 5.3	356 / 14.0	173 / 6.8	HPW-0300	9 / 20
DN100	4"	52.0 / 2.00	128 / 5.0	135 / 5.3	385 / 15.2	186 / 7.3	HPW-0400	11 / 24
DN150	6"	56.0 / 2.20	220 / 8.7	193 / 7.6	451 / 17.8	218 / 8.6	HPW-0600	14 / 30
DN200	8"	58.0 / 2.30	220 / 8.7	193 / 7.6	508 / 20.0	252 / 9.9	HPW-0800	15 / 32

Butterfly Valve (Wafer) with Gear Operator - HPW

Materials List

Item	Description	Material	Specification
1	Body	Ductile Iron, EPDM encapsulated	BS2789 ASTM A536
2	Disc	Ductile Iron, nylon coated	BS2789 ASTM A536
3	Upper and Lower Stems	Stainless Steel	AISI 420
4	Worm Gear Shaft	Stainless Steel	AISI 420
5	Gear Housing	Ductile Iron	BS2789 ASTM A536
6	Handwheel	Ductile Iron	BS2789 ASTM A536
7	Flag Indicator	Ductile Iron	BS2789 ASTM A536
8	Segment Gear	Bronze	ASTM B148 or B584
9	Shear Pin	Steel	ASTM A510
10	Gasket and O-rings	EPDM Rubber, grade "E"	

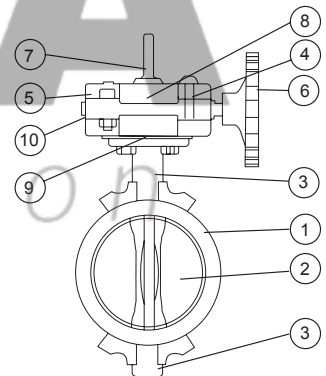



Butterfly Valve (Wafer) with Gear Operator

HPW

Design requirements

The butterfly valve should be connected to the piping system with approved couplings or flanges available from Viking SupplyNet. Flow may be from either direction through the valve, and the valve may be positioned in any direction. The gearbox has been designed with a slow close handwheel operator that effectively minimizes water hammer during the opening or closing of valve during flow conditions. These valves feature minimum flow restriction and pressure loss when in the fully open position.

Installation

When the valves are received from Viking SupplyNet they should be handled carefully to avoid breakage and damage to the seating area. Before installation of the valve, clean the piping, and connecting flange or coupling. Care must be taken to align wafer butterfly valves correctly in the middle of the waterway so as not to impair disc operation nor damage the disc or operator. Place the two flanges parallel to each other with a distance between them that is slightly larger than the valve takeout. Insert two studs through the bottom two holes of both flanges. Slide the butterfly valve into the space between the two flanges and place the trunion of the valve such that it rests between the two studs. The studs should support the valve by slipping into the two notches on either side of the valve trunion. Ensure the valve is centered in the waterway. Insert the remaining studs around the valve and

tighten in an alternating fashion until the desired torque is achieved.

To prevent distortion, properly support the piping adjacent to the inlet and outlet of the valve. Avoid damage and do not use the valve to force the piping into position.

The valve should never be forced to seat by applying excessive torque to the gearbox or through the use of a wrench. This may distort the valve components or score the sealing surface. Care must be taken to align wafer valves correctly so that the disc operation to the fully open position will not be obstructed. The use of excessive force to open or close the valve violates all warranties whether express or implied.

Conduit and electrical connections to the supervisory/auxiliary switches must be in accordance with the requirements of the Authority Having Jurisdiction.

Care and Maintenance

Inspect and verify proper operation on an annual basis or according to the requirements of the Authority Having Jurisdiction. Check for leakage at the valve pipe connection and body-to-operator connection. Installation, inspection and maintenance should be performed by a qualified person(s) certified by the Authority Having Jurisdiction.

If the valve closes hard, check to make sure that there is no debris lodged in the waterway around the seating area. Backing off the handwheel and closing the valve again can often correct this condition.

Butterfly Valve (Wafer) with Gear Operator - HPW

Wiring Instructions

The HPW series butterfly valves come complete with one internal supervisory position switch and one internal auxiliary switch.

The supervisory/auxiliary switches operate by a cam connected to the valve stem and are designed to notify in the case of valve closure. Please refer to the relevant installation standard and Authority Having Jurisdiction.

The switches will change position and close within two (2) full turns of the hand wheel from the fully open position.

Switch number	Wire	Wire color	Mode/Description
Supervisory switch #1	A	Yellow	Normally open
Supervisory switch #1	B	Red	Normally closed
Supervisory switch #1	C	White	Common
Auxiliary switch #2	D	Blue	Normally open
Auxiliary switch #2	E	Orange	Normally closed
Auxiliary switch #2	F	Black	Common
	G	Green	Ground lead

Notes : Connection to power limited circuitry is required. Switch rating is limited to 5 A, 1/6 HP, 125 V or 250 V

